



華晶精密工業有限公司

FLYGIN CO.,LTD.



機械軸封 & 迴轉接頭 & 疏水閥

Mechanical Seals & Rotary Joints & Steam Traps

<http://www.flygin-lhs.com>

[Http://www.lhs0955887677.com](http://www.lhs0955887677.com)



蒸汽迴轉接頭-101

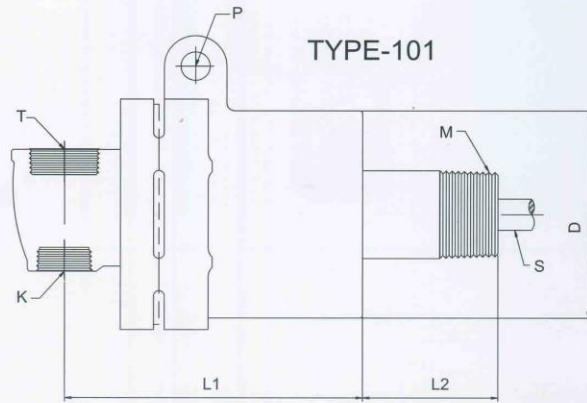
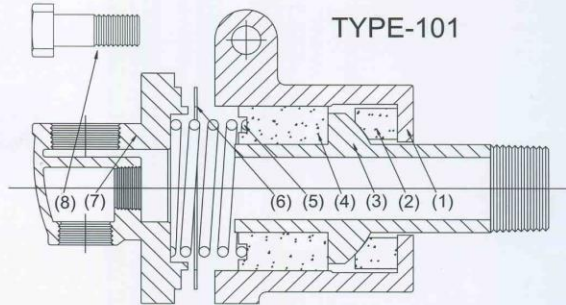

迴轉接頭

| PARTS/COMPONENTS 零件 / 名稱 | | MATERIAL 材 質 | |
|-----------------------------|-----------------|-----------------|--------|
| 1 | MAIN BODY 本體 | CAST IRON | 鑄 鐵 |
| 2 | SEAL RING 封環 | CARBON | 石 墨 |
| 3 | SHAFT 軸心 | SUS 304 | 不鏽鋼304 |
| 4 | BEARING 培林 | CARBON | 石 墨 |
| 5 | SPRING 彈簧 | SUS 304 | 不鏽鋼304 |
| 6 | PACKING 迫緊 | ASBETOS | 石 棉 |
| 7 | TOP COVER 上蓋 | CAST IRON | 鑄 鐵 |
| 8 | SET SCREW 螺絲 | CARBON ST | 碳 鋼 |

| 規格尺寸 / NOMINAL SIZE | | | | | | | |
|---------------------|---------|---------|----------|---------|---------|----------|----------|
| M PT | T PT | K PT | S PT | P MM | D MM | L1 MM | L2 MM |
| 1/2" | 3/8" | 3/8" | 1/4" | 9 | 65 | 88 | 38 |
| 3/4" | 1/2" | 1/2" | 1/4" | 9 | 72 | 108 | 40 |
| 1" | 3/4" | 1/2" | 3/8" | 11 | 80 | 112 | 51 |
| 1 1/4" | 1" | 1/2" | 1/2" | 14 | 92 | 145 | 55 |
| 1 1/2" | 1 1/4" | 3/4" | 3/4" | 14 | 118 | 167 | 60 |
| 2" | 1 1/2" | 1" | 3/4", 1" | 14 | 127 | 180 | 63 |
| 2 1/2" | 2" | 1 1/4" | 1" | 17 | 153 | 200 | 70 |
| 3" | 2 1/2" | 1 1/4" | 1 1/4" | 21 | 178 | 220 | 79 |



蒸汽迴轉接頭-303

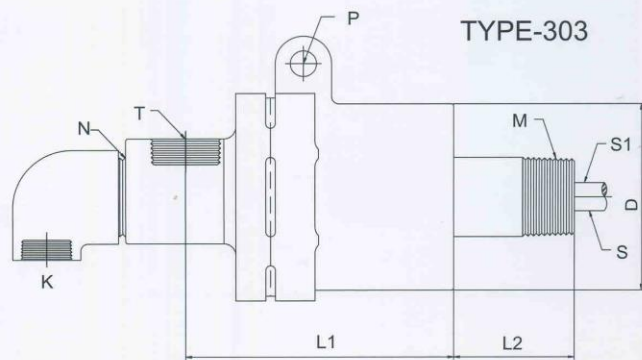
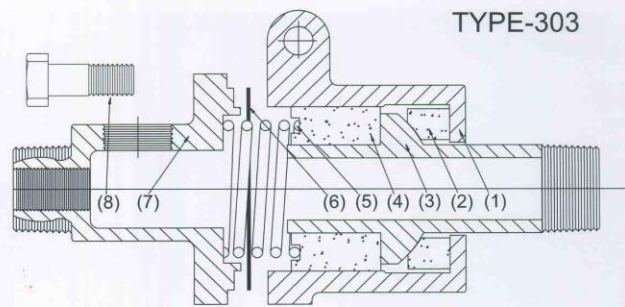

迴轉接頭

| PARTS/COMPONENTS 零件 / 名稱 | | MATERIAL 材 質 | |
|-----------------------------|-----------------|-----------------|--------|
| 1 | MAIN BODY 本體 | CAST IRON | 鑄 鐵 |
| 2 | SEAL RING 封環 | CARBON | 石 墨 |
| 3 | SHAFT 軸心 | SUS 304 | 不鏽鋼304 |
| 4 | BEARING 培林 | CARBON | 石 墨 |
| 5 | SPRING 彈簧 | SUS 304 | 不鏽鋼304 |
| 6 | PACKING 迫緊 | ASBETOS | 石 棉 |
| 7 | TOP COVER 上蓋 | CAST IRON | 鑄 鐵 |
| 8 | SET SCREW 螺絲 | CARBON ST | 碳 鋼 |

| 規格尺寸 / NOMINAL SIZE | | | | | | | | | | |
|---------------------|---------|---------|---------|------------|---------|---------|----------|----------|---------------|--|
| M PT | N PT | T PT | K PT | S PS | P MM | D MM | L1 MM | L2 MM | S1 KEY WAY | |
| 1/2" | 1/2" | 3/8" | 3/8" | 1/4" | 9 | 65 | 88 | 38 | | |
| 3/4" | 3/4" | 1/2" | 1/2" | 1/4" | 9 | 72 | 108 | 40 | | |
| 1" | 1" | 3/4" | 1/2" | 3/8" | 11 | 80 | 112 | 51 | φ17.5x6寬x3深 | |
| 1 1/4" | 1 1/4" | 1" | 1/2" | 1/2" | 14 | 92 | 145 | 55 | | |
| 1 1/2" | 1 1/2" | 1 1/4" | 1" | 3/4" | 14 | 118 | 167 | 60 | | |
| 2" | 2" | 1 1/2" | 1" | 3/4", 1" | 14 | 127 | 180 | 63 | | |
| 2 1/2" | 2 1/2" | 2" | 1 1/4" | 1", 1 1/4" | 17 | 153 | 200 | 70 | | |
| 3" | 3" | 2 1/2" | 1 1/4" | 1 1/4" | 21 | 178 | 220 | 79 | | |



水用迴轉接頭-505



水用迴轉接頭-707



油用迴轉接頭-909

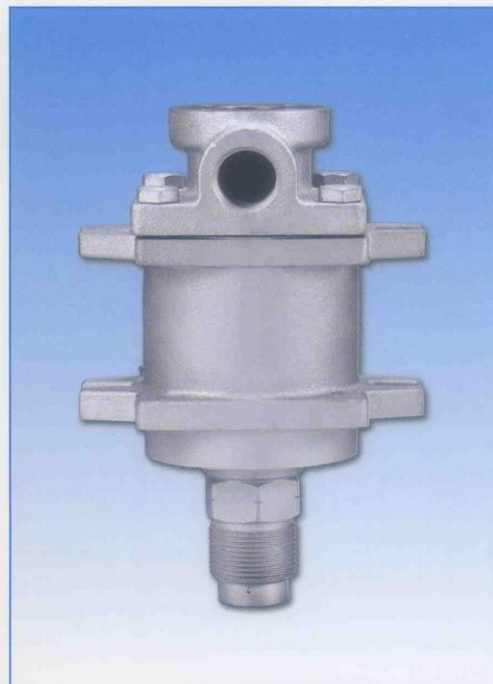

迴轉接頭

材質尺寸表

| | 505 | 707 | 909 |
|-------------------------|--------------------------|------------------|------------------|
| 材 質 MATERIAL | SUS304 不鏽鋼304 | SUS304 不鏽鋼304 | F.C.D. 石墨鑄鐵 |
| 規 格 尺 寸 NOMINAL SIZE | 材質: 鋁 $\frac{3}{8}$ " | $\frac{3}{4}$ " | $1\frac{1}{4}$ " |
| | $\frac{1}{2}$ " | 1" | |
| | $\frac{3}{4}$ " | | |
| | 1" | | |
| | | | |
| | | | |
| | | | |

華晶精密工業有限公司

TEL:(03)365-1035 FAX:(03)365-1032

水用迴轉接頭:505- 3/8"

廠牌: FLYGIN 材質:鋁 圖面如下:



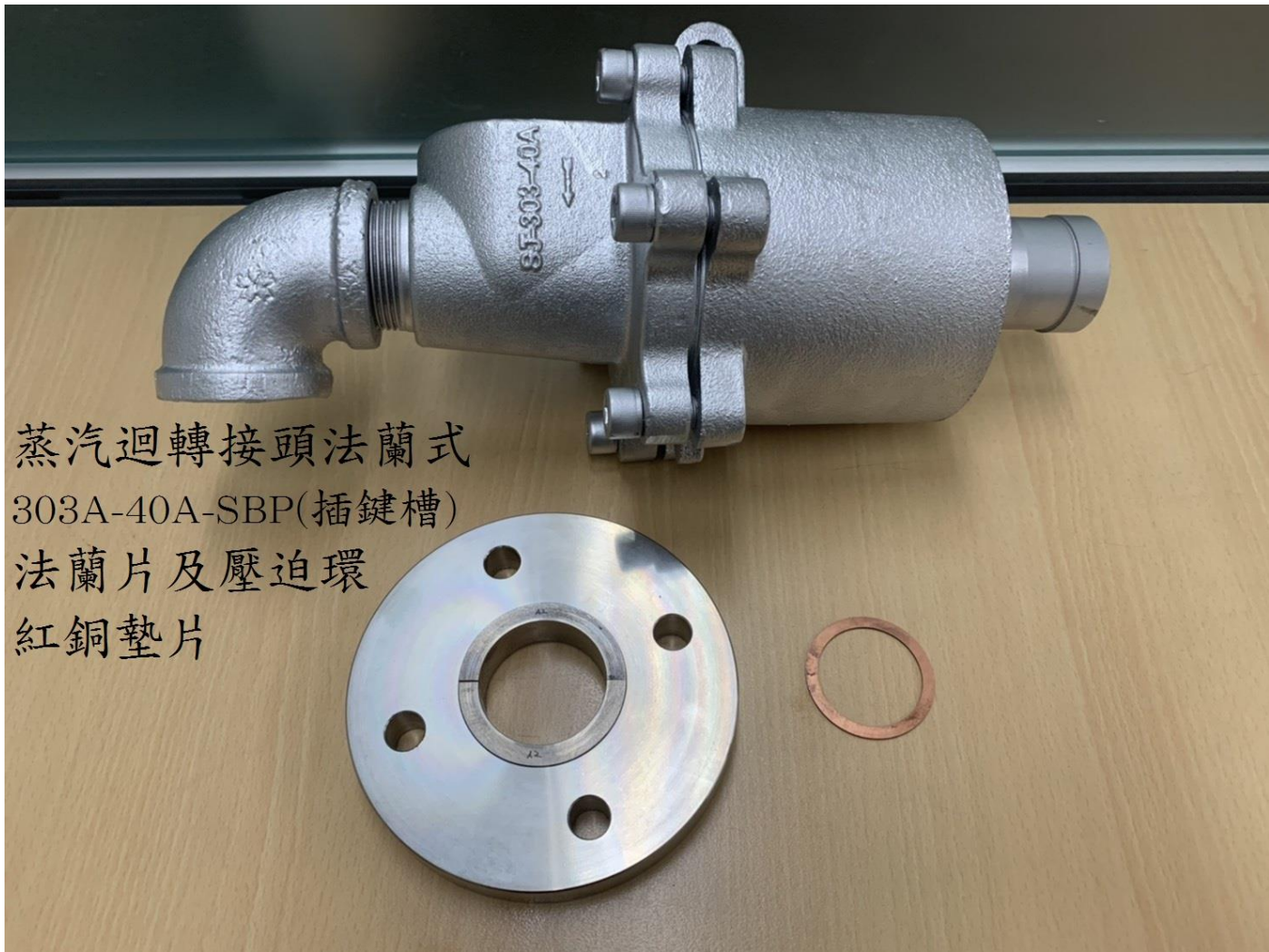

蒸汽迴轉接頭法蘭式
303A-40A-SBP(插鍵槽)
法蘭片及壓迫環
紅銅墊片



華晶精密工業有限公司
FLY GIN CO.,LTD

統一編號: 27585462

網址:<http://www.flygin-lhs.com>

E-mail:a0955887677@yahoo.com.tw

電話:(03)365-1035 ~37

傳真:(03)365-1032

地址:334 桃園市八德區豐成街16號